

Geo-engineering and geotechnical engineering challenges from the sustainable development of the city of Chongqing, China

YINGZHONG GUO¹

¹ Faculty of Civil Engineering, Chongqing University. (e-mail: gyz3188@tom.com)

Abstract: Chongqing is the largest city on the upper reaches of the Yangtze River, situated in the reservoir region of the Three Gorges Project, the largest water conservancy project ever built in the world.

Since March 14, 1997 as the fourth municipality with Beijing, Tianjin and Shanghai directly under central government control, Chongqing has entered a newly developing period. Compared with the other municipalities, Chongqing has the largest population, the largest rural area and, thus, a relative backward development of the economy, and has taken on the quite arduous task of moving and setting a million migrants from the region. In addition, it ranks the first of 70 mountain cities where the strongest geohazards, landslide and dangerous or unstable rock occur in China and is a key area where the geohazards have to be prevented and controlled.

The challenges for geo-engineering and geotechnical engineering faced by the sustainable development of the city of Chongqing are the prevention and control of the geohazards, and the urgent solution of the four major problems of geotechnical engineering respectively.

To meet the challenges and achieve success in them, with some case histories of the engineering, this paper discusses the following points from the strategic point of view:

- Definitions of geotechnical engineering and geo-engineering as a discipline name and a technical term in engineering respectively and their interrelation from the point of view of engineering;
- Theoretical and realistic significance of the study of geo-engineering and geotechnical engineering;
- Main problems and basic theory of the study of the two engineering areas;
- Basic knowledge to be possessed by intermediate and senior technicians of geo-engineering and geotechnical engineering and, therefore certain reformations of higher education;
- Certain case histories reflecting geo-engineering, geotechnical engineering and their interconnection.

Résumé: La Ville de Chongqing est la ville la plus grande sur l'amont du Fleuve Yangtsé qui se trouve dans la région des travaux hydraulique de Trois Gorges du Fleuve Yangtsé et les derniers sont des travaux hyduliauxques les plus grands du monde jusqu'à présent.

Le 14 mars, la Ville de Chongqing est devenue la 4^{ème} ville autonome relevant directement au gouvernement central après Beijing, Tianjin et Shanghai, par rapport à d'autres villes autonomes, la Ville de Chongqing compte une population plus nombreuse et une superficie de campagne plus vaste, le développement économique est relativement moins avancé, elle a une mission importante : traitement des paysans riverains quittant leur pays natal dû à la construction des travaux hydrauliques des Trois Gorges du Fleuve Yangtsé ; parmi les 70 villes qui ont des sinistres géologiques les plus sérieux, la Ville de Chongqing se trouve en première.

Le défi des travaux géologiques et de terrain rocheux pour le développement durable de Chongqing est : prévention des sinistres géologiques et 4 travaux de terrain rocheux à résoudre :

Pour faire face au défi et connaître de succès, ce texte explique les 4 points suivants :

1. Définition des travaux de terrain rocheux et des travaux géologiques ainsi que leur relation réciproque au niveau de la perspective des travaux;
2. La théorie et l'objectif de la recherche des travaux de terrain rocheux et des travaux géologiques ;
3. Problématique principale et théorie élémentaire pour la recherche de ce domaine des travaux ;
4. Connaissances élémentaires munies par les techniciens supérieurs et ordinaires des travaux de terrain rocheux et des travaux géologiques et réforme de l'enseignement supérieur ;
5. Cas réels des travaux de terrain rocheux et des travaux géologiques et leurs relations réciproques ;

Keywords: megacities, geotechnical engineering, geological hazards, slope stability, foundations, bearing capacity

INTRODUCTION

In general, slow construction and economic development in mountainous cities and townships firstly result from the occurrence of geohazards, such as landslide, dangerous or unstable rock, caving bank, mudflow, etc., and from dispersed or scattered land, which cannot to be utilized easily, by the obstructions caused by mountain ranges and by rivers, streams and gullies. Transportation routes are also underdeveloped. To utilise the ground surface, one has to cut hills and fill gullies in some cases so as to form some high cuts and fill slopes. This may eveno induce new geohazards to occur. In China, Chongqing is such a typical mountainous city.

The reservoir region of the Three Gorges Project stretches along the Yangtze River from the west, Chongqing to the east, Sandouping of Yichang city, Hubei province and its total length is 594 km and the Chongqing section of the region does from the west, main urban district of the city of Chongqing to the east, Wushan county, making up about 81% of the total length of the region. Chongqing is a megacity and since 14 March 1997, as the fourth municipality

with Beijing, Tianjin and Shanghai directly under central government control, has entered a new development period. Under its jurisdiction, there are 43 districts and counties, and over 100 townships in the Chongqing section. It covers an area of 82,000 km² and its main urban district or urban core is the centre of politics, economy, culture and education. Among the 70 mountainous cities in China where the strongest geohazards, such as landslide and dangerous or unstable rock slopes occur, Chongqing ranks first.

The Chongqing section can be divided into two subsections in terms of landform: one is low mountains, hills and broad valleys to the west of Fengjie county, its elevation varying from the west of 400-600 m, to the east of 800-1000 m, and another is middle and lower mountains and gorges to the east of Fengjie county, its elevation varying from 1000 to 1500m. According to investigation, there are 404 rockfalls and landslides in the region with each with a volume of 1×10^4 m³ or more, and the total volume of 3.06×10^9 m³ on the two banks of the Yangtze River and its main tributaries from Chongqing to Yichang, with the landslides being mainly distributed in the broad valley zone from Chongqing to Fengjie.

The challenges for the geo-engineering and geotechnical engineering in Chongqing involve the following four major problems: 1. Appraisal of the stability of slopes and comprehensive control of unstable slopes as poor or bad foundation soils or rocks for building, road, bridge, harbour, dam, etc.; 2. Treatment and improvement of any other types of poor or bad foundation soils or rocks for the usages above; 3. Appraisal of the stability of rocks surrounding underground openings proposed and treatment of foundation soils or rocks surrounding openings; 4. Comparison, selection and optimisation of the feasibility and economic effect of the schemes for design of the foundation soil or rock and foundation, and substructure.

DEFINITION AND MAIN PROBLEMS OF STUDY OF GEO-ENGINEERING AND GEOTECHNICAL ENGINEERING

Definitions of geotechnical engineering and geo-engineering

This section is actually ready to answer what is the starting point for meeting the challenges, i.e. making sure what are the academic and technical dividing lines between geo-engineering and geotechnical engineering. The definitions have two kinds of meanings, one referring to a discipline name and another, to a technical term.

In 1998 Braja M.Das in his book "Principles of Geotechnical Engineering" defined geotechnical engineering as follows: 'Geotechnical engineering is defined as a sub-discipline of civil engineering that involves natural material found on the surface of the earth. It includes the application of the principles of soil mechanics and rock mechanics to design of foundations, retaining structures and earth structures'. It is evident that his definition of geotechnical engineering refers to a discipline. From this point of view, geotechnical engineering, just like geo-engineering, is actually a multidiscipline or a discipline group consisting mainly of three sub-disciplines, engineering geology, mechanics of soil or rock, and structural engineering. Different from geotechnical engineering, geo-engineering is a sub-discipline of geology that is a branch of natural science dealing with the earth, especially the earth's crust, and aimed at studying the theory, technology and methods for prevention and control of those poor or bad physico-geological phenomena, earthquake, landslide, rockfall, mudflow, karst, etc. Study of geotechnical engineering or geo-engineering is, in essence, an academic activity.

Another definition of geotechnical engineering is regarded as a technical term of engineering, namely geotechnical engineering is a technical assembly, serving a special-purpose engineering, of the investigation of geotechnical engineering, selection and design of the schemes and construction of foundation or substructure, with the special-purposed engineering referring to those engineerings related to construction of national economy, building engineering, road and bridge engineering, water conservancy projects, mine engineering, etc., and with the foundation meaning the infrastructure of a specific building or structure. Similarly, from the point of view of engineering, geo-engineering refers also to a technical assembly but, serving engineering for the prevention and control of geohazards, of the investigation of engineering geology, selection and design of the schemes of the engineering and construction of retaining and draining structures, etc. In terms of sub-discipline combination, there is basically no clear difference between geo-engineering and geotechnical engineering and they both consist of the same three subdisciplines mentioned previously. In practical work, these two engineering sub-disciplines are both related to, and different from, each other, and sometimes it is hard to draw an obvious dividing line between them.

In China the academic and technical concepts of geotechnical engineering and geo-engineering tend to easily make one confused and therefore recognition of their relationship and difference, especially in mountainous areas, is essential for meeting the challenges.

Main problems of the study of geotechnical engineering

This section intends to answer how to meet the challenges and to achieve success from them.

The sites for the study were mainly chosen in the cities and townships in the Chongqing section and the ideal one is the main urban district, a peninsula located at the confluence of the Jialing and Yangtze Rivers where along the banks of the two rivers landslides and dangerous or unstable rocks occur concentrically in the four zones (Figure 1) whereas in the broad rolling-hill area, taking up 57.4% of the total area of the district, are distributed the multilayered close-spaced underground openings for air defence to have been built since the War of Resistance.



Figure 1. Distribution of the geohazards in the main urban district, Chongqing

1. River valley low land; 2. Hill; 3. Low mountain; 4. River flow direction, Jialing river (upper) and Yangtze river (right); 5-8. Zhenjiangsi-Hongyandong, Nanqulu-Caiyuanba, Liziba-Hualongqiao, and Dadukou Chongqing steelworks, key areas for prevention and control of dangerous rocks and landslides

In China sustainable urbanization is a way the city construction and development must pass through and it requires construction of a 'compact-type' city so as to save the land resource, protect the environment and coordinate the relationship between the saving of the land and protection of the environment, and the development of the society and national economy, as shows clearly such prospects of Chongqing sustainable urbanization: creation of subjective and objective conditions to open and utilize the underground space mainly situated in the main urban district as quickly as possible; and improvement and utilization of the sloping land as a type of poor or bad foundation soil or rock on both banks of the Yangtze and Jialing rivers, where there is both dense population, near buildings and highway cutting through the district, and the potential for landslides, dangerous or unstable rocks. Realization of such prospects must solve the foregoing major four problems, which is the challenge for geo-engineering and geotechnical engineering for the sustainable development of the city of Chongqing. To meet the coming challenges and solve the major problems, the following main subjects are worthy of study:

Rock mechanics properties of soft and weak intercalation and discontinuity in rock masses

Among the structural units in rock masses, the ones that dominate the types of structure and physico-mechanical properties of rock mass are the soft and weak intercalations and discontinuities, respectively. In the Chongqing area, the soft and weak intercalations of sandstone and mudstone and the IV, V class discontinuities, i.e. areal structural joints and microfissures in feldspathic sandstone in the strata of the Upper Shaximiao Formation, (Jurassic System), can be taken as the main object to be studied. The contents for the study include: 1. testing in situ (such as CT etc.) to understand the spatial distribution of discontinuities with the test accuracy in accordance with the requirements of the national code "Investigation of Geotechnical Engineering;" 2. compilation and development of a 3D CAD program of the geological structure caused by ground stress, such as folding, faulting, jointing, etc.; 3. analysis of rock-mechanical properties of discontinuities and its sensitivity factors; 4. calculation of the deformation and strength of the rock mass; and 5. establishment of the constitutive relationship of stress vs strain for the rock mass.

3D numerical analysis of the stability and the lateral earth or rock pressure of a slope and the thrust of a landslide

Real observation and engineering practice indicate that the failure of a slope occurs only within a 3D limited range. The 2D idealized explanation and analysis of the stability of a slope are both conservative and widely divergent from practice and tend to lead to difficulty in deciding how to draw up a scheme for control of a slope, the design of the slope and the construction budget for slope engineering concerning high rise and complex buildings, cuttings, riverside buildings and structures, mine engineering, engineering for flood prevention, etc. The objects to be studied are the typical soil, rock and soil with rock interbedded slopes. The contents for the study are: 1. 3D numerical analysis of the stability of a slope under the influence of the factors, such as a rear tensile fissuring, especially full of water, groundwater, seismic force, anchoring, etc., and 3D numerical calculation of the lateral earth or rock pressure of a slope and the thrust of a landslide; 2. the principles of, and optimum scheme for, anchoring dangerous or unstable rocks or unstable blocks on a slope; and 3. optimum anchorage workmanship.

The mutual effect of superstructure, foundation and foundation soil or rock

Traditional design tends not to consider the deformation compatibility between the structure, foundation and foundation soil or rock, but is usually made merely on the basis of the method of safety factor; i.e. using experience where subjective factors are generally dominant. This design not only results in the serious waste of manpower and material resources owing to its conservative nature but leads to the failure of buildings and even injuries and deaths.

This study not merely makes structural design accord with the principles“economy, safety, rationality and feasibility”but promotes the reformation, deepening and development of the theory of calculation of the traditional design of a building or structure. The contents for the study involve: 1. the numerical calculation theory and measuring method considering the mutual effect for correctly determining the values of those parameters for substructure design, such as the thickness of safety of the overburden overlying the top surface of a subgrade or foundation soils or rocks surrounding one or several underground openings, the rational interval between or among the openings, etc.; 2. comparison, selection and optimisation, considering the mutual effect, of the schemes of the foundation soil or rock and foundation for building, road, bridge and harbour and, of the schemes of the lining and retaining structures, etc. of underground openings (especially those at shallow depth, with large spans and significant jointing) in accordance with their feasibility and economy; 3. control and improvement, considering the mutual effect, of the poor or bad subgrade or foundation soils or rocks for buildings, road, bridges and harbours, respectively; and 4. appraisal, considering the mutual effect, of the stability of a foundation.

The structures with both anti-slip retaining and load-bearing effects

This key subject is aimed at adapting or suiting the comprehensive control of bad or poor foundation soils or rocks and at improvement of the behaviour of both anti-slip retaining and load-bearing structures. The main topics to be studied are anti-slip piles, retaining walls, prestressed anchor ropes and anchor bars or bolts, single-pile or pile group foundations, high-strength concrete, reinforced earth, geotechnical fabrics, anti-corrosion material, etc. The aspects for the study include: 1. the mechanical mechanism of, and CAD calculation of the internal force, reinforcement, strength and rigidity of those anti-slip retaining structures, such as eccentric-and-hollow large diameter anti-slip piles, anti-slip retaining walls with anchor pile groups, small-intermediate diameter close-spaced anti-slip piles, prestressed anchor ropes, cantiliver pile-with-anchor pile anti-slip structures, H type anti-slip piles, matrix-borehole guniting curtains, V-like pile-and-beam assembled anti-slip structures, reinforced earth retaining walls, etc.; 2. the workmanship of construction of the structures of interest; 3. mechanical mechanism of, and pseudo-true study of, the structures with both anti-slip retaining and load-bearing effects; 4. the behaviour and manufacturing techniques of new-types of structural materials; and 5. comparison, selection and optimisation of the schemes for the comprehensive control of an unstable building slope or a landslide as a poor or unstable foundation soil or rock.

Deepening and extending of the monitoring of geotechnical engineering

Monitoring of geotechnical engineering consists of monitoring the deformation and displacement of the superstructure, foundation and foundation soil or rock.

The focal or key objects to be studied are the two zones of the main urban district, one being the zone of the banks along the two rivers where both high rise buildings and traffic highway, and dangerous or unstable rocks and landslide are rather concentrated, and another being the broad rolling-hill zone to be reformed and developed where underground openings are closely distributed or at shallow depth. The contents for the study are: 1. model of the analysis and prediction of geotechnical engineering; 2. setting up the database of geotechnical engineering; and 3. objective imitation of geotechnical engineering.

Optimum management of geotechnical engineering

Geotechnical engineering is a systematic subject closely related to the development of the national economy and to the safety of the life and property of the people and concerning multidisciplinary activity and multitechnology, such as mathematics, physics, chemistry, astronomy, geology, biology, etc. Among various parts of geotechnical engineering, management is given first place to.

Statistical data indicate that during construction of geotechnical engineering, for example, construction of cuttings and explosion, if not following state-stipulated capital construction procedure poor or bad artificial engineering action tends to become a main factor inducing geohazards, such as “engineering landslides” or “engineering dangerous or unstable rocks” to occur. To prevent this kind of artificial engineering action from inducing geohazards, it is necessary and urgent to realize the objectivity, institutionalization and automatization of the management. Realization of the optimum management depends on the Chongqing authorities at all levels and the functional department involved.

The contents for the study are: 1. establishment of a database for the management; and 2. applying the technology and method of artificial intelligence to develop various kinds of computer systems as “machine experts”.

FUNDAMENTAL KNOWLEDGE FOR THE STUDY OF GEOTECHNICAL ENGINEERING AND GEO-ENGINEERING

To adapt to the requirements of the study of geotechnical engineering and geo-engineering for planning and development of Chongqing cities and townships, the traditional knowledge structure should be improved and renewed. As for intermediate and senior, equivalent Mr and Dr. ranked, technicians engaged in geotechnical engineering and geo-engineering, they should possess or master the fundamental theoretic knowledge as shown in Figure2.

In viewing certain special studies or research, this theoretical knowledge still needs deepening and developing, and is tested and verified, replenished and perfected further in practical work. Under the present conditions, to make the intermediate and senior researchers and technicians arrive at such knowledge levels needs them to undergo a comparatively long term process of accepting re-education. This is concerned with the complex higher education reformation, i.e “strengthening students’s, both the undergraduated and the graduated, quality education, dimming the

line of demarcation among specialities and fostering or cultivating student's multifunction in our country". Furthermore, geotechnical engineering and geo-engineering are both part covered or full covered, closely related geological environment involved, and will be influenced by many unknown and stochastic or random factors during construction. Therefore "practice first and close combination of theory with practice" should be the essential quality possessed firstly by the researchers and technicians. To satisfy the urgent needs of the tasks of construction of the cities and townships including moving and settling down of the migrants, and prevention and control of geohazards, especially the landslide, dangerous or unstable rock and caving bank of the Chongqing section, more realistic course of action is to try one's best to facilitate and encourage cooperation or combination of the personnel engaged in geo-engineering, geotechnical engineering and structural engineering respectively, and in investigation, design and construction respectively.

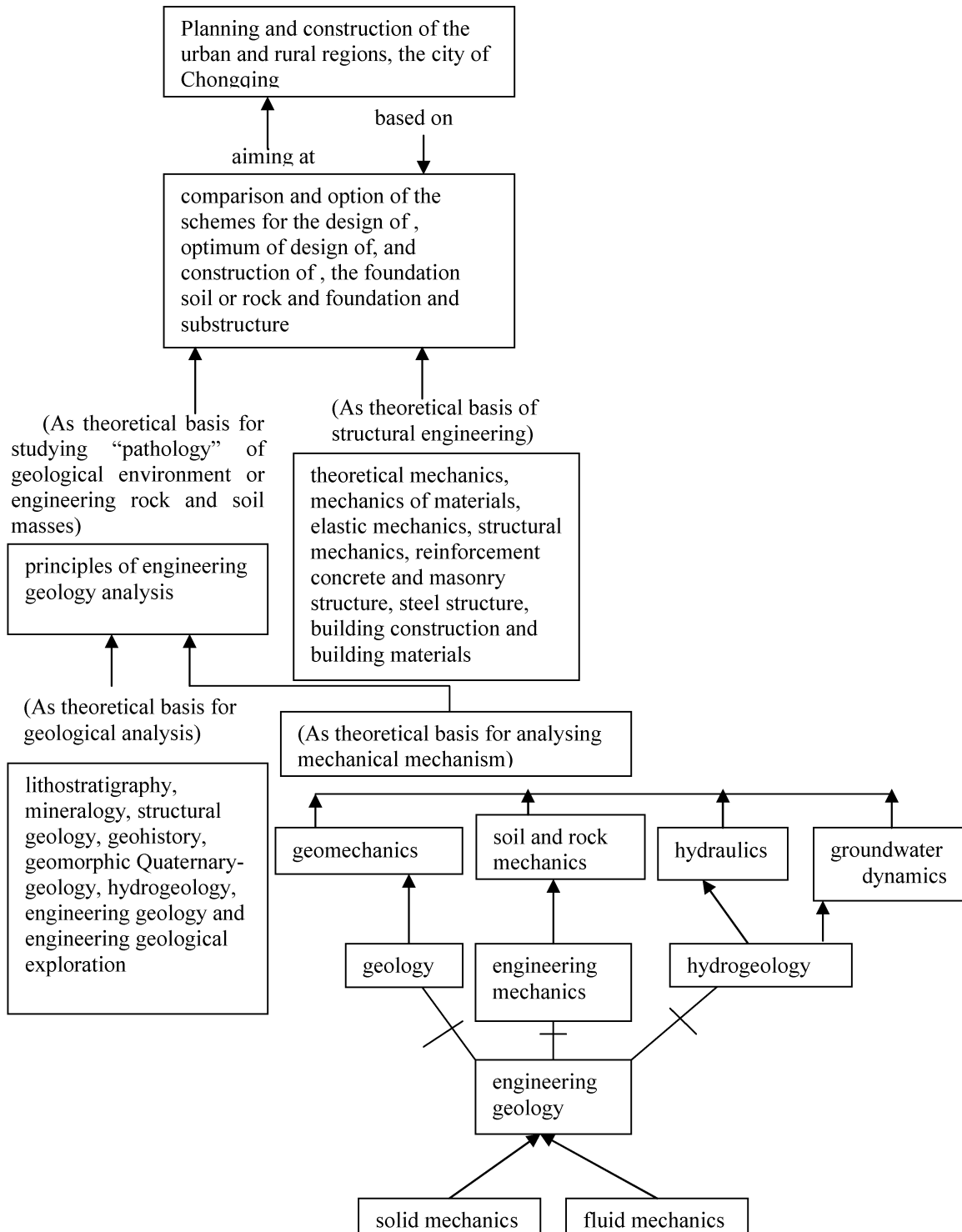

Figure 2. Basic theoretical knowledge for study of geotechnical engineering in Chongqing

CASE HISTORIES OF ENGINEERING INTEREST

Case history of geotechnical engineering

This case history shows the study of geotechnical engineering for the soft foundation soils in a residential quarter or housing estate for the purpose of reformation of the Caiyuanba block, in the main urban district.

The distribution of stress and the characteristics of the strength and deformation of the soft foundation soils in the quarter and the option and design of the optimum scheme of a foundation overlying the soils are presented briefly as the following:

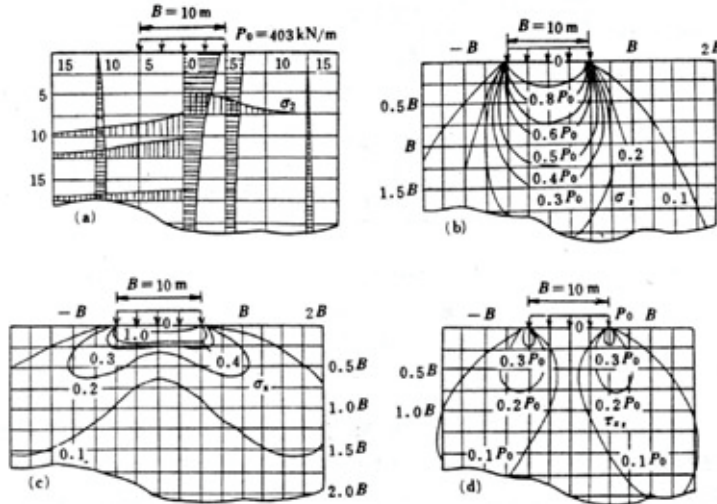

Figure 3. Additional stress distribution in the soil underlying a strap footing under the action of uniformly distributed load (a) σ_z distribution on the horizontal planes at various depths (b) σ_z isoline, (c) σ_x isoline, and (d) τ_{xz} isoline

Characteristics of the stress distribution of a soft foundation soil

This time the vertical deformation or settlement is mainly studied resulting from the vertical stress σ_z . As shown in Figure 3(b), the isoline of $\sigma_z = 0.1 \rho_0$ (ρ_0 being additional pressure due to building load only acting on the base of a foundation) has reached bedrock. Furthermore the thickness of a gravel layer is variable and thus selection of the bedrock as a bearing stratum comparatively rational.

Option and design of the optimum scheme of a foundation

Based on the analysis and calculation of the characteristics of the strength, i.e. bearing capacity and deformation, i.e. settlement of the soft foundation soils, proposed the optimum scheme for the design of a foundation in Table 1.

Table 1. Optimum foundation scheme

| Building No. | 1 | 2 | 3 | 4 | 5 |
|---|------------------|-----------|-----------|-----------|-----------|
| Building area(m ²) | 37596 | 20139 | 8394 | 8732 | 11261 |
| Structure type | Frame-shear wall | Frame | Frame | Frame | Frame |
| Story number | 18-26 | 7 | 7 | 7 | 10 |
| Condition about underground installation and basement | Basement | | | | |
| Maxium of load on a single column(KN) | 15000 | 5000 | 5000 | 5000 | 5000 |
| Sensitivity of building to settlement | Sensitive | Sensitive | Sensitive | Sensitive | Sensitive |
| Optimum foundation type | ① | ①② | ① | ①② | ① |
| Remarks | [1] | [2] | | | |

*For the 18-story building, try to design the optimum scheme by scheme ② and if satisfying the requirements of both bearing capacity and settlement the scheme ② is to be added as an optimum scheme of the foundation for No.1 building

†If both drainage of groundwater and ventilation good, scheme ① refers to a bored pile or an excavation pile foundation and scheme ② means a single-column cross beam foundation overlying an artificial foundation soil

Make the design of a single-column cross beam foundation overlying of an artificial foundation soil for No.1 18-story building following the procedures below at that time:

1. determining the size of a foundation base and ultimate bearing capacity of a foundation soil;

2. distributing loads acting on a cross beam;
3. designing JL-1 longitudinal foundation beam; and
4. designing JL-2 transverse foundation beam.

Case histories showing combination of geotechnical engineering with geo-engineering

Chongqing Liziba engineering for both widening a road surface or pavement and controlling a landslide

The structure adopted in this engineering consists of eccentrically hollow anti-sliding pile, upright stanchion or prop and arched panel spanning between the two stanchions then was as both a anti-sliding retaining structure for control of a landslide and a load-bearing structure for widening a pavement or road surface as shown in Figure 4. At that time the design of this structure was based on the following thinking, i.e. since the pile was subjected to thrust of a landslide bent towards the Jialing river and deviated from the pavement or road surface of the Jialing arterial highway it could be regarded as a structural member or element in bending. From this point of view, concrete on the inner side towards the highway of the neutral axis of the pile is in tension and thus can be removed out from the side to a maximum extent without much affecting the tensile strength of the pile, for concrete is very weak in tension. As for concrete the amount used in all the cast-in-situ hollow piles decreased to 75% of that in all the cast-in-place solid piles so that the engineering resulted in a reduced construction cost of about 600 thousands yuan (Y600000). The landslide has been stable so far so as to have ensured that traffic is unimpeded.

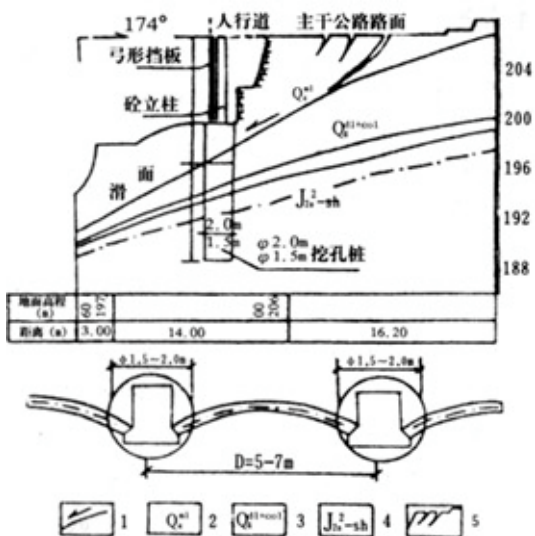

Figure 4. Anti-sliding-and-load bearing structure (after Chongqing institute of the investigation, design and research of municipal works)

1. sliding surface and its sliding direction; 2. artificial backfill, Q_4^{ml} Quaternary System; 3. colluvium and slope wash, Q_4^{dl+col} Quaternary System; 4. Upper Shaximiao Formation, Middle Jurassic System J_{2s-sh}^2 ; 5. tensile cracks on the pavement of the Jialing arterial highway

Engineering of the super high rise building of Chongqing Bureau of Power Industry

This site for the engineering was located then on a sloping fields of the 3rd-stepped erosive terrace on the north bank of the Yangtze River, in the main urban district. Ground investigation, boring and upright excavation shaft all proved that at the site where there was a shallow bedrock landslide consisting of the 2nd section (J_{2s}^s) of the Upper Shaximiao Formation, (Jurassic System).

The measures for protecting the pavement of the Jialing traffic arterial highway and for handling or treating foundation rock were then as follows: unloading a slope mass, retaining with anchor and repairing drainage system. In structural measure a circular tube structure was adopted as the structural form of the 22-story high rise building and as a whole embedded firmly down into the stable bedrock in a sliding bed just like a huge anti-sliding pile, both load-bearing and slide-resisting, so as to have played a role in stabilizing the slope mass. Moreover, before cutting and unloaded the slope where both the building rested and the rocky landslide existed it was protected by adopting enlarged excavation pile on the rear edge of the landslide mass. During construction the excavation of the foundation pit was directed by deformation monitoring and the inspection of the completion of the engineering was up to standard at that time. The operation of the building has been normal so far.

Furthermore, the riverside Jialing arterial highway that cut through the sloping fields, where both dangerous or unstable rocks and landslides occurred on the bank of the Jialing River has had no problems.

CONCLUSION

From the discussion one can understand at least what are the challenges, and how to meet the challenges and to achieve success from them in the Chongqing area..

Construction of cities and townships and economic development of the Chongqing section is very important for the economic development of western China's vast and relatively poor areas and for the successful completion of the Three Gorges Project.

With the advance of sustainable development of urbanization of the city of Chongqing, the study and practice of geotechnical engineering and geo-engineering will be very important.

Corresponding author: Prof Yingzhong Guo, Faculty of Civil Engineering, Chongqing University, 83 North Street, Shapingba, Chongqing, 400045, China. Tel: +86 023 65432150. Email: gyz3188@tom.com