

Disease of bridge on the highway road 108 in the west of China (Guangyuan) and its reinforcement measures

YUN-JIE WEI¹ MO XU² & DE-MIN XU³

¹National Laboratory of Geo-hazard Prevention and Geo-environment Protection, Chengdu University of Technology, Chengdu, Sichuan province, 610059 (e-mail:wyj1973@126.com)

²National Laboratory of Geo-hazard Prevention and Geo-environment Protection, Chengdu University of Technology, Chengdu, Sichuan province, 610059 (e-mail: xm@cdut.edu.cn)

³National Laboratory of Geo-hazard Prevention and Geo-environment Protection, Chengdu University of Technology, Chengdu, Sichuan province, 610059 (e-mail: xudemin2004@163.com)

Abstract: Severe cracking is a common feature of bridges structures forming the Guangyuan section of National Road No.108. Cracking is thought to be due to the combination of geology, geomorphology, high loads and poor construction. The geological conditions along this section of the road are introduced in the paper. A genetic classification of the cracking is proposed; cracking due to poor backfilling around the upper part of the abutment; cracking due to poor backfilling behind the entire bridge abutment; and cracking due to differential settlement. For each case different remedial measures were adopted, comprising: grouting, structural reinforcement using pre-stressed anchors/ties, and jet grouting. All three types of remedial measures have been used successfully to strengthen the bridge structures and prevent further cracking. The merits of the measures are their simplicity and low cost. The origin and distribution of cracking is difficult to assess. In order to ensure the quality of the remedial measures it is necessary to take cores after “mud-jacking” and “high pressure spouting” and to ensure that the holes drilled to take the “opthread-pre-stressed strand anchors” are strictly controlled.

Résumé: Les ponts formant la section de Guangyan de la route nationale n°108 ont pour caractéristique commune d'avoir de graves fissures. Ces fissures sont probablement dues à une combinaison de facteurs géologiques, géomorphologiques, de charges élevées ainsi que d'une construction de mauvaise qualité. Les conditions géologiques particulières de cette section de la route sont exposées dans l'article. Une classification de la genèse des fissures y est proposée; fissures en raison du faible remblai se trouvant autour de la butée; fissures en raison du faible remblai se trouvant tout autour de la butée du pont; et fissures en raison des divers positionnements. Pour chaque cas, des mesures réparatrices ont été adoptées, comprenant: grouting, renforcements structurels en utilisant des tirants/ancrages passifs; et jet grouting. Ces trois types de mesures correctives ont été utilisées avec succès pour renforcer les ponts et prévenir d'éventuelles fissures. Le plus grand mérite de ces mesures est leur simplicité et leur coût peu élevé. Il est difficile de déterminer l'origine et l'emplacement des fissures. De manière à assurer la qualité des mesures de réparation, il est nécessaire d'enlever les échantillons après avoir effectué le grouting et jet-grouting et de s'assurer que les trous forés pour prendre le renforcements structurels en utilisant des tirants/ancrages passifs sont strictement contrôlés.

Keywords: highways; drilling; safety; testing; monitoring; settlement

INTRODUCTION

The Guangyuan section of National Road No.108 extends along the Jialing River and its western tributary, the Qianxi River. The Jialing and Qianxi rivers are both located in a deeply eroded gorge. The road is characterised by deep cuttings and embankments with many bridges and culverts. Soon after opening, cracking, believed to be due to the combination of geology, geomorphology, high loads and poor construction, became apparent. In order to maintain road safety it was necessary to adopt a range of remedial measures consisting of grouting; structural reinforcement using pre-stressed anchors/ties and, jet grouting. In order to benefit from the experience gained in implementing these remedial measures in a mountainous area in Western China, a summary of the key controlling factors is given in this paper.

ENGINEERING GEOLOGICAL SETTING

The Guangyaun section of National Road No.108 was constructed between 1994 and 1997. The road runs along the west bank of the Jialing River and the Qianxi River, its tributary near Chaotianyi County. Between Ciyao and the Longdongbei District, both the Jialing and Xiqian rivers are in a deeply eroded canyon. The valley sides are steep and craggy. However, between Longdonbei and Qipanguan, the Qianxi River is deeper, the valley wider and the slopes lower and less steep.

Geologically, the road is located on the fringe of the Longmen Mountain Tectonic Zone, which has experienced three phases of structural deformation: the Caledonian Epoch, the Indo-Chinese Epoch and the Yanshan Epoch. Movements during the Caledonian and Yanshan Epochs induced an unconformity. Uplift and intense deformation

during the “Indo-Chinese Epoch” resulted in a discordant contact between Jurassic and Triassic strata and also a series of compound folds. The geology comprises strata of Silurian, Permian, Triassic, Jurassic and Quaternary age. The Quaternary comprises alluvial and colluvial sediments (landslides and slumping-slope wash) distributed along the river valleys (river bed, terraces and the foot and middle parts of the valley sides).

DESCRIPTION OF CRACKING AND REMEDIAL MEASURES

Types of cracking

The Guangyuan section of the National Road No.108 has been in operation for three years. Cracking has appeared in bridge structures in the arch wall, fore-wall, lateral wall and also in the road surface. On the basis of investigations, three main types of cracking have been identified.

Type 1 - Cracking due to poorly compacted backfill in the upper part of the bridge abutment, which under heavy load results in subsidence of the road, cracking and seepage. In turn this has led to deterioration of the “back of arch material” and squeezing and ripping of the lateral walls.

Type 2 - Cracking where clay has been used inside the entire bridge abutment as backfill material. The clay has been poorly compacted, is of low density, with a high porosity and weak structure. Under heavy loads, the integral bridge abutment has settled and the lateral wall and cone slope have deformed and cracked.

Type 3 - Differential settlement due to differing foundation materials. In one case, an abutment has been founded on backfill which settled more than the other corresponding abutment. In another case, where the Quaternary deposits are thicker closer to the river, loose soil has not been removed from beneath the abutment resulting in greater settlement. In both cases, cracking and displacement of the abutment is present in the abutment which has settled less.

REMEDIAL MEASURES

On the basis of the investigations, new techniques have been introduced, which have proven that the techniques of grouting, anchors and jet grouting are a good way to prevent further deterioration.

Grouting was adopted in the case of Type 1 cracking; grout has been injected into the pore space of the soil and cracks in the concrete, improving strength and load carrying capacity. The technique is simple and expenditure low.

For Type 2 cracking, the structural stability of the abutment was improved by a method of structural reinforcement using anchors/ties. Grouting could not be used on these structures because it is limited by depth.

Where cracking is due to differential settlement, jet grouting was adopted which creates columns of mixed cement grout and soil. This method improves the strength and stiffness of the foundation and prevents further cracking occurring.

EXAMPLE OF TYPE 1 CRACKING

Description of damage

This bridge (K8+523) is a single arch overbridge, with a length of 30m, width of 10m and a mid-arch height of 20m. Observations of distress in the bridge were as follows:-

During trials, under heavy load, the integral bridge was severely damaged. The masonry walls were damaged and the wall and foundation cracked. In the right hand side of the bridge there is a lateral crack in the “arch bridge wall and arching” 3 mm to 15 mm in width. The crack is wider in the arch and narrower in the sidewall.

The masonry strength was found to be lower in one side. The backfill has been poorly compacted in the “upper foundation”. Under load, the road has subsided, causing cracking and water penetration and inducing extrusion of the side-walls and cracking. A vertical crack 3 to 5 m long is apparent in each sidewall.

Remedial Measures

Grouting was considered appropriate for this structure to improve the arch body supporting load ability and assure arch body continuity and integrality and to improve the stability and stiffness of the backfill. After the grout has set, anchor rods were introduced to improve the strength of the side-walls, as follows:

1. Ten (10) injection holes within the arch body are arranged in a plum blossom shape, into which cement paste is poured.
2. The bridge abutment backfill has been mud-jacking reinforcement using ten (10) vertical (grout) injection holes spaced 2m apart from the road surface.
3. Once the grouting is complete and the grout set, anchors, 6 to 7 m long, spaced 1 to 1.5 m apart are installed. There are a total of 49 anchor bars arranged in 7 columns.

After observation for more than one year, the cracks in the abutment sidewall, fore wall and arch body have not worsened and the designer is satisfied with the work.

EXAMPLE OF TYPE 2 CRACKING

Description of damage

This structure is the abutment to Shahe Overpass Bridge (K9+694.10) and located in an old river channel belonging to the Jialing River. The ground conditions beneath the left side of the bridge comprise 9.5m to 10m of alluvial silt and silt containing gravel overlying a boulder bed or rock. The right side of the bridge is founded on Jurassic sandstone. Differential settlement has occurred due to the presence of inhomogeneous soil beneath the foundations. Settlement of the left foundation has resulted in damage to the fore wall and sidewalls and dislocation of the right abutment. There is a slanting crack in the road surface.

Remedial Measures

The relatively soft soil beneath the subsiding foundation needed to be strengthened to prevent further differential settlement and continued cracking. Since the cause of the settlement lies below the foundation the jet grouting method was adopted.

The jet grout columns are located according to the upper load and the actual foundation situation and extend vertically downwards 0.5 m into gravel or original rock. The upper part of the columns is at the level of the bottom of the original bridge abutment. The columns were spaced 1.2 to 1.5 m apart and have a diameter in excess of 0.5 m. There are two rows of columns in the left road, four rows on the road surface and two rows under the bridge. A total of 101 columns were installed.

Results

Following construction of the jet grout columns and after 28 days, three columns were selected at random for coring. A core sample with a length of 70 to 250 mm was taken from a hole drilled 300 mm into the centre of the column and the integrity of the sample inspected. The top of the column was confirmed to cling to the bridge abutment and the sample found to have a compressive strength of 5.9MPa. Continued observation of the bridge abutment indicates that no further cracking has occurred.

EXAMPLE OF TYPE 3 CRACKING

Description of damage

Songjiagou Bridge is located in the town of Zhongzi, it has a length of 45m, width of 13.5 m, arch height of 21m and arch span of 16m. The bridge is of masonry construction and backfilled with soil. During trial, deformation occurred in the bridge abutment and cone slope. The sidewall was found to have displaced 4 m and the cone slope cracked. Several cracks 1 to 20 mm wide were apparent in the bridge abutment protection bars (parapet) and the arch wall. The length of the slant spread is 8 to 10 m indicating a trend of gradual deterioration.

Selection of the strengthening measures

The U-shaped (in plan) bridge abutment is constructed of a concrete and grout masonry mixed structure. The bottom of the foundation is cast in concrete. Both sidewalls are made of masonry (blockstone and limestone) with soil backfill between them. The backfill is of varying composition mainly of efflorescent shale and clay. The fill exterior to the bridge abutment is of similar composition.

The cause to the cracking is thought to be due to the poorly compacted backfill, which has a loose structure and high void ratio. Water penetrating the structure has caused the backfill to swell reducing its strength and lowering its bearing capacity. Subsidence due to traffic load has subsequently occurred. Lateral compression of the backfill has resulted in deformation of the sidewalls and cone slope.

Grouting was performed to prevent further road subsidence. Unfortunately, sidewall displacement and cracking in the arch wall continued. The depth of grouting is limited (4 to 8 m) and it is thought that the cause of the cracking is due to backfill material below this level. Consequently, structural reinforcement using anchors/ties has been adopted to reinforce the bridge structure.

Bridge reinforcement

Bridge reinforcement was carried out in the following manner:

1. Twenty-six (26) 130 mm diameter anchor boreholes were drilled horizontally on a 3 m x 3 m grid pattern into the bridge abutment sidewalls. The holes were arranged in four horizontal rows; with four holes in the first two rows, three holes in the third row and two holes in the fourth row (Figure 1).
2. Horizontal and vertical beams are used to span the holes in each sidewall. Holes have been preformed in the centre of each beam, with sufficient space to allow for adjustment on site. The upper anchor beam is 600 mm wide and 300 mm thick and the other anchor beams 400 mm wide and 300 mm thick. The length of the beam depends on the geometry of the sidewall.

Results

The bridge abutment has been monitored and has now been in operation for more than one year. Further distortion of the bridge abutment and cone slope has been prevented and cracking halted proving successful implementation of the method.

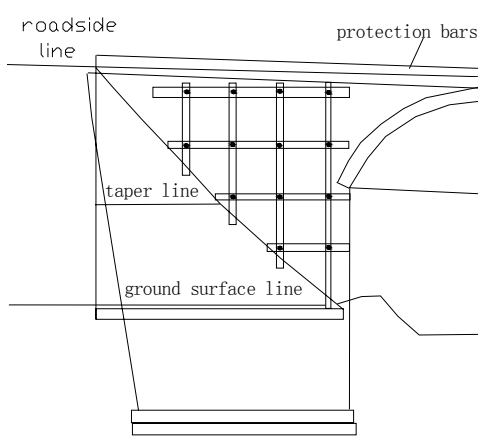

Figure 1. Layout of structural reinforcement using anchors/ties, Songjiagou Great Bridge

CONCLUSION

As a result of the complex geology, topographical features, the possible influence of earthquake loads and poor construction, cracking occurred on a number of bridges in the Guangyuan section of National Road No.108. Due to the large number of bridges and culverts on this section of road cracking is more prevalent in the district than in others. On the basis of field investigations a genetic classification of the cracking has been proposed; cracking due to poor backfilling around the upper part of the abutment; cracking due to poor backfilling of the behind the entire bridge abutment; and cracking due to differential settlement. For each case different remedial measures were adopted, comprising grouting, structural reinforcement using pre-stressed anchors/ties and jet grouting. All three types of remedial measures have been used successfully to strengthen the bridge structures and prevent further cracking. The merits of the measures are their simplicity and low cost. The origin and distribution of cracking is difficult to assess. In order to ensure the quality of the remedial measures it is necessary to take cores after grouting and jet grouting and to ensure that the holes drilled to take the pre-stressed anchors/ties are strictly controlled.

Corresponding author: Dr Wei Yunjie, Chengdu University of Technology, Erxian Bridge, Chengdu, Sichuan, 610059, China.
Tel: +86 2884078954. Email: wyj1973@126.com