

# Evaluation of geohazards for stripped top soil and rock disposal on a slope

DUOWEN DING<sup>1</sup>

<sup>1</sup> Morgan State University. (e-mail: dding@eng.morgan.edu)

**Abstract:** Due to the constraint of the geographical environment and construction and mining costs, stripped top soil and rock often needs to be disposed on slopes near to a construction site or mine in a geologically permanent manner. During the development of such tips, the engineering geological, hydrogeological, and geometrical parameters of the slope gradually change. This process of slope development, and the effect of the slope on its surrounding environment, is the main concern of designers. In this paper, factors such as precipitation, climate, ground water level, slope surface shape, slope internal structure, and the installation of drainage have been combined in a physical model that has been constructed to simulate possible geohazards such as soil erosion, mudslides, and slope instability. Based on results from this model, the likelihood of slope erosion and mudslides can be minimised, slope stability maximized and the design of a slope optimized to satisfy environmental requirements.

**Résumé:** A cause des problèmes d'environnement géographique et des constructions et des prix des mines, on a placé les roches et les terres à côté des moraines près des constructions et des mines à une manière géographiquement ordonnée. Et puis, on développe les calculs géographiques, hydrogéologiques, et géométriques graduellement. Dans le processus de la calcul du slope, la principale question pour le designer c'est l'effet du slope sur les changements environnementaux. Dans cette dissertation, les facteurs telles que le changement de la précipitation du climat, l'eau au dessous de la terre, la forme de la surface du slope, l'intérieur du slope structure, et l'installation du drainage sont importants pour la partie physique du modèle. Toutes ces facteurs calculés et conçus sont fabriqués pour simuler le géohazard possible telles que, l'érosion du sol, la boue, la stabilité du slope. Quand on diminue l'érosion du slope, des terres mouillées (la boue), on augmente la stabilité du slope. On ajuste le slope par lui-même et optimise pour satisfaire le standard de l'environnement basé sur l'information de la simulation.

**Keywords:** slope stability, soil erosion, landslides, geological hazards, seepage, environmental impact.

## INTRODUCTION

For reasons of cost and space, it is common to dispose of stripped topsoil and fine rock from a mining excavation on a slope surrounding an open pit mine. The increased thickness of materials on the slope changes the geological and hydrologic conditions of the slope by modifying the thickness of material overlying bedrock, slope angle, runoff, and position of the water table. Such changes to the slope may increase the risk of geological hazards such as soil erosion, landslide and debris flows. These types of geological hazards can cause severe damage in the area below the slope and affect agriculture, infrastructure, commercial buildings, industrial facilities and residential property. In order to evaluate the potential risk of geohazards, this paper discusses the design of a physical model to simulate the geological and hydrologic conditions for a slope. This physical model is helpful for the prediction of the long-term slope stability and in helping optimization of the slope geometry. The following sections discuss the design of the physical model, the test data, and the analysis of the results and have used geological and hydrological data for the Panle iron mine.

## GEOGRAPHICAL, GEOLOGIC AND HYDROLOGIC CHARACTERISTICS OF PANLE IRON MINE

Figure 1 provides a topographic map for a tip at the Panle iron mine. The original topography of the tip area comprised two slopes which formed a gully orientated about south 45° west. The materials forming the slopes comprise fractured granite bedrock overlain by a 0.5~2m thick layer of superficial deposits. Before placing the stripped topsoil and rock on the slope, the original superficial materials overlying the fractured bedrock were removed. A number of springs occur in the gully and their position is shown in Figure 1. The maximum outflow from a spring is 1.5~1.8 l/sec. Maximum concentration measured at the toe of the slope is 7.8 l/sec. The average rainfall density in the area is 540 mm/year, and the maximum rainfall density is 144mm/day. The original bedrock slope is stable. The slope angle of the tip is 35°. The slope height is about 230m. The maximum slope length is about 610m. The maximum thickness of the tip is 98m and the maximum width of the tip is 280m. The particle size distribution of the stripped topsoil that forms the tip is given in table 1. The data in table 1 show that about 10% to 15% by weight of the stripped topsoil comprises large grain sizes, with 34% to 89% by weight comprising gravel, and 31% to 54% by weight sand, silts and clays. The dry density, moist density (wet density), hydraulic conductivity, cohesion, and frictional angle of the stripped soil and bedrock are shown in table 2. The main concern for the tip is the potential risk of geohazards such as slope failure, mudflow, and soil erosion.

## DESIGN AND FABRICATION OF A PHYSICAL MODEL

### Scaling in Slope Model Design

In order to design a model of a slope, the scaling relationship between the model and field case or prototype being assessed must be established (Munson et al.). The main requirements for the model are to ensure a scale relationship between: 1) the shape and geometry of the bedrock surface 2) the shape and geometry of the tipped material, 3) material composition, 4) physical and mechanical properties, 5) permeability, and precipitation, and 6) surface and groundwater flow patterns.

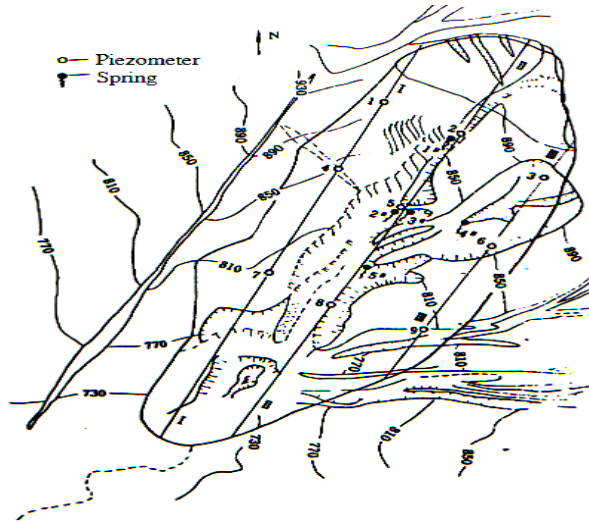

The volume rate ratio  $a_o$  is

$$a_o = a_A a_v = a_1^2 a_v = 90000 \quad (4)$$

where  $a_A$  is the cross section area ratio of the field case and model (i.e.,  $A_p/A_m$ ). The precipitation velocity scale  $a_v$  can be computed from permeability velocity scale as follows

$$a_{v1} = a_v = 1 \quad (5)$$

If the precipitation velocity scale  $a_{v2}$  can be calculated based on impulse-momentum equation, we have

$$a_{force} = a_p a_A a_{v2}^2 \quad (6)$$

where  $a_{force}$  is the erosion force ratio and  $a_A$  is the area ratio.

Let  $a_{force} = 1$ , then  $a_{v2}$  is 1/300 on the basis of equation 6. In order to demonstrate both erosion and seepage effect of heavy rain on the model slope, the precipitation velocity ratio  $a_{v2}$  was chosen as 1/300.

### Model Fabrication

The model consists of the bedrock surface overlain by the tipped topsoil materials. The bedrock surface was modelled using concrete with cracks incorporated into the model to simulate the fractured rock mass. The number and width of the cracks in the concrete model were modelled to give an equivalent hydraulic conductivity to that of the fractured bedrock. A similar shape and geometry for the model bedrock was used to ensure similarity with the existing slope and gully. The strength of concrete was close to the strength of the bedrock. A simulated spring was incorporated into the model at the position of spring #1 and the outflow volume rate for the model  $Q_{max}$  ( $8.7 \times 10^{-5}$  l/sec) computed from the volume rate of the field case and the volume rate ratio. Material sampled from the tip on site was used to build the model. The material from site was compacted and remoulded to have the same specific weight, hydraulic conductivity, and shear strength parameter values as measured in the field. At the same time, the other scaling requirements were also met. A water tank at the back of the model was used to apply a hydraulic head and to generate flow through the simulated fractures in the bedrock. Two hydraulic heads within the model were chosen (20 cm and 30 cm). Water spray nozzles were used to simulate heavy rainfall. The flow velocity through the nozzles was selected as 30mm/min and reflected the scaled maximum daily precipitation of 144mm and the precipitation velocity ratio 1/300. The length of the model was 2.1m, the width 0.93m and the height of 0.93m. A diagram of the slope model is shown in Figure 2.

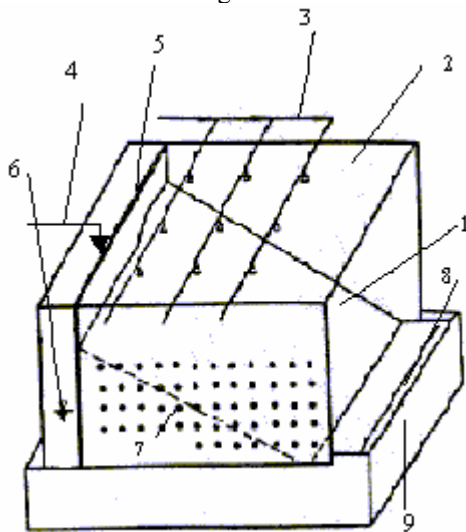

**Figure 2.** Model of Stripped Topsoil Tip for Measurement of Erosion and Stability. Legend: 1 – Slope, 2 – Slot, 3 – Water Pipe, 4 – Water Pipe of Tank, 5 – Copper Web, 6 – Water Tank, 7 – Piezometer Tube, 8 – Flow Slot, and 9 – Base

### INSTRUMENTATION AND MEASUREMENT

The flow to the fracture at the base of the model was fed from the water tank at the back of the model and the value of the acting hydraulic head is taken from the manometer on the wall of the water tank. The water level is controlled by a manual valve. A water pipe buried in the model is used to simulate the springs. The volume rate readings for spring flow in the model are taken from the Venturi meter connected to the water pipe. The intensity of the rainfall through the spray nozzles can be controlled using Venturi meters and valves. Piezometers are used to measure the phreatic surface in the model. At the start of the modelling, water is allowed to flow into the slope model to simulate fracture flow and spring water flow. Following this, the effect of heavy rain falling on the slope is simulated by using the sprinklers. During this time the phreatic surface in the model is monitored. As the test proceeds, the slope

deformation and pore water head readings are manually collected from the side of the model and the piezometers respectively.

## OBSERVATION, ANALYSIS AND DISCUSSION

### Hydraulic Head Distribution

The hydraulic head applied at the back of slope was either 20cm or 30cm. The volume of water fed to the spring was 0.3 l/hour. First, the 20cm hydraulic head was applied to the model and the height of the phreatic surface measured. Once this had stabilised the 30cm hydraulic head was applied and the spray nozzles started to spray water onto the slope to simulate heavy rain. When the slope face saturated the spray water was stopped. The measured phreatic lines from the test are shown in Figure 3.

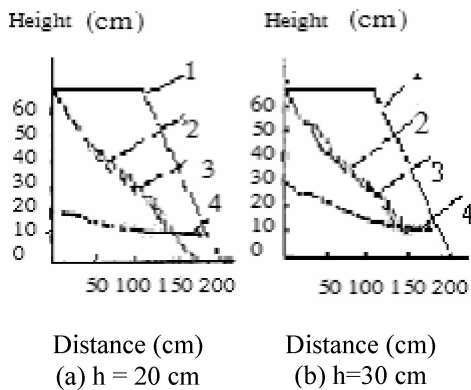

Figure 3. Hydraulic Head Distribution of Section II - II

### Soil Erosion and Stability Analysis

From slope modelling and hydrologic simulation, the following observations were made:

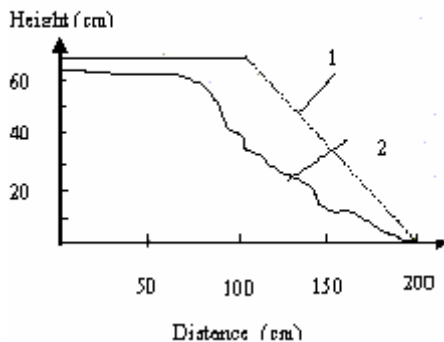

Figure 4. Slope Deformation Process (1 – before simulation, 2 – after simulation)

For the test where the hydraulic head was set at 20 cm and included the effects of fracture flow from bedrock and surface flow from a spring there was limited effect on the slope which remained stable. In this case, the soil layer at the toe of slope was wet but was not completely saturated due to the filter at the toe of the slope. The deformation observed on the surface of the model slope was small.

For the test where the hydraulic head was increased to 30 cm, some surface erosion of small particle sizes ( $\phi < 0.5\text{mm}$ ) was observed. In this model, the soil layer at the toe of slope was saturated and cracks developed at the top of the slope. The top surface of the slope subsided by about 0.7 cm, although overall, the whole slope remained stable.

For the test where the hydraulic head was 30cm and where water was sprayed onto the slope surface to simulate precipitation some soil particles were eroded by runoff. The geometry of the final slope surface is shown in Figure 4.

For the third case, the shape of the slope surface changed significantly because of erosion and the failure of the slope caused by seepage from the subsurface flow and runoff from surface flow. The final slope angle of the upper part of the slope was  $39^\circ$ , while that of the middle part of the slope was  $30^\circ$  and the slope angle of the low part was  $23^\circ$ .

Based on the results of the simulation, it was concluded that the geometry of the tip could be revised to have three slopes that reflected the geometry of the failed surface. These angles respectively are  $39^\circ$ ,  $30^\circ$ , and  $23^\circ$ . It was

concluded that a slope designed to such angles may show better stability against slope failure and a lower potential risk for soil erosion, mudflow and debris flow than the existing design of the slope.

**Acknowledgements:** The author is grateful to Panle iron mine for the constant support and partnership in research.

**Corresponding author:** Dr Duowen Ding, Morgan State University, PKWY 5200, Baltimore, Maryland, 21251, United States of America. Tel: +1 410 661 8535. Email: [dding@eng.morgan.edu](mailto:dding@eng.morgan.edu).

## **REFERENCES**

- LOMIZE, G. M. (1951), Seepage through fractured rocks, Gosenergoizdat, Mosco.  
MESRI, G., AND OLSON R. E. (1971), Mechanism controlling the permeability of clays, *Clay Miner.*, vol. 19, pp. 151- 158.  
DAS, B. M. (1997), *Advanced soil mechanics*, Taylor & Francis.  
MUNSON B. R., et al. (1994), *Fundamentals of fluid mechanics*, John Wiley & Sons, Inc